SPECIFICATION FOR CERAMIC COB LED

Part No: LCSC1215-05W0XXXXFR80-0320

Description:

12*15mm COB LED

Dice Material: InGaN

Confirmed by Customer:_____

Approved by

Checked by

Prepared by

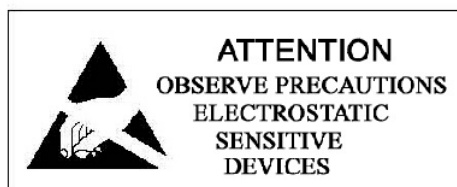

LCSC1215-05W0XXXFR80-0320

High CRI Series COB LED

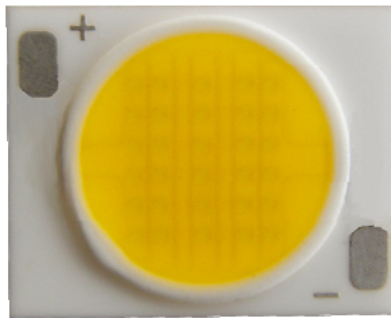

Introduction

High CRI series LED Light engine is based on our main patent----- **MCOB** (**M**ulti-**C**hips **O**n **B**oard) . Lumiere LEDs combine tens or hundreds power LED chips with a rugged package capable of operating in excess of power . Lumiere LEDs maximumly decrease LED uncomfortable glare and also Zebra strips, at the same time increase LED light efficiency and reduce thermal resistance.

Features:

- ◇ Area light source, which can avoid glare
- ◇ More energy efficient than incandescent , halogen and some fluorescent lamps
- ◇ Industry's lowest thermal resistance
- ◇ Long operating life, lumen maintenance of greater than 70% after 50,000 hours
- ◇ Low forward voltage operated
- ◇ Instant light (less than 100ns)
- ◇ Lead Free product, RoHS compliant
- ◇ No UV

Application

- ◇ Automotive interior / exterior lighting
- ◇ Automotive signal lighting
- ◇ General Torch
- ◇ Architectural lighting
- ◇ LCD TV / Monitor Backlight
- ◇ Projector light source
- ◇ Traffic signals
- ◇ Task lighting
- ◇ Decorative / Pathway lighting
- ◇ Remote / Solar powered lighting
- ◇ Household appliances

Outline Dimensions:

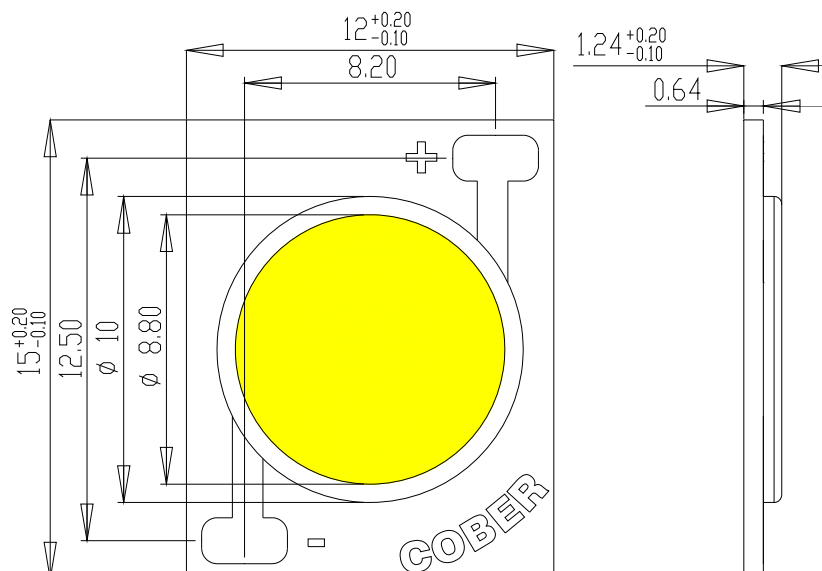

LCSC1215-05W0XXXFR80-0320

Absolute Maximum Ratings at Ta=25°C:

Parameter	Part No.	Symbol	Maximum	Unit
Power Dissipation	LCSC1215-05W0XXXFR8 0-0320	Pd	6.5	W
Peak Forward Current (1/10 Duty Cycle,0.1ms Pulse Width)		IF(max.)	360	mA
Continuous Forward Current		IF(Typ.)	280	mA
LED junction temperature		JT	115	°C
case temperature		Tp	100	°C
Reverse Voltage		VR	25	V
Thermal Resistance, junction to case	LCSC1215-05W0XXXFR8 0-0320	Rθ j-c	2.5	°C/W
Soldering Temperature °C	5 seconds, 260°C or lower			
Operating temperature range		Topr	-30°C to + 85°C	
Storage Temperature Range		Tstg	-40°C to + 100°C	

● Electro-optical characteristics at Ta=25°C

Parameter	Part No.	Symbol	Test Condition	Min.	Typ.	Max.	Unit
Color Rendering Index	LCSC1215-05W0XX XXFR80-0320	CRI		75		80	
Viewing Angle		2θ1/2			140		deg
Forward Voltage		V _F	I _F =320mA	14		17	V
Reverse Current		I _R	V _R =25V			15	uA
Color Temperature- 2700K		CCT		2580	2725	2870	K
Luminous flux		φ	I _F =320mA	450	510		lm
Color Temperature- 3000K		CCT		2870	3045	3220	K

Luminous flux	ϕ	$I_F=320mA$	460	520		lm
Color Temperature- 4000K	CCT		3710	3985	4260	K
Luminous flux	ϕ	$I_F=320mA$	470	530		lm
Color Temperature- 4500K	CCT		4260	4503	4745	K
Luminous flux	ϕ	$I_F=320mA$	480	540		lm
Color Temperature- 5000K	CCT		4745	5028	5311	K
Luminous flux	ϕ	$I_F=320mA$	480	540		lm
Color Temperature- 5700K	CCT		5310	5665	6020	K
Luminous flux	ϕ	$I_F=320mA$	480	540		lm
Color Temperature- 6500K	CCT		6020	6530	7040	K
Luminous flux	ϕ	$I_F=320mA$	470	530		lm

- 1、 The luminous intensity data did not include $\pm 10\%$ testing tolerance.
- 2、 Tolerance of CRI is ± 2 .

Relative Spectral Power Distribution

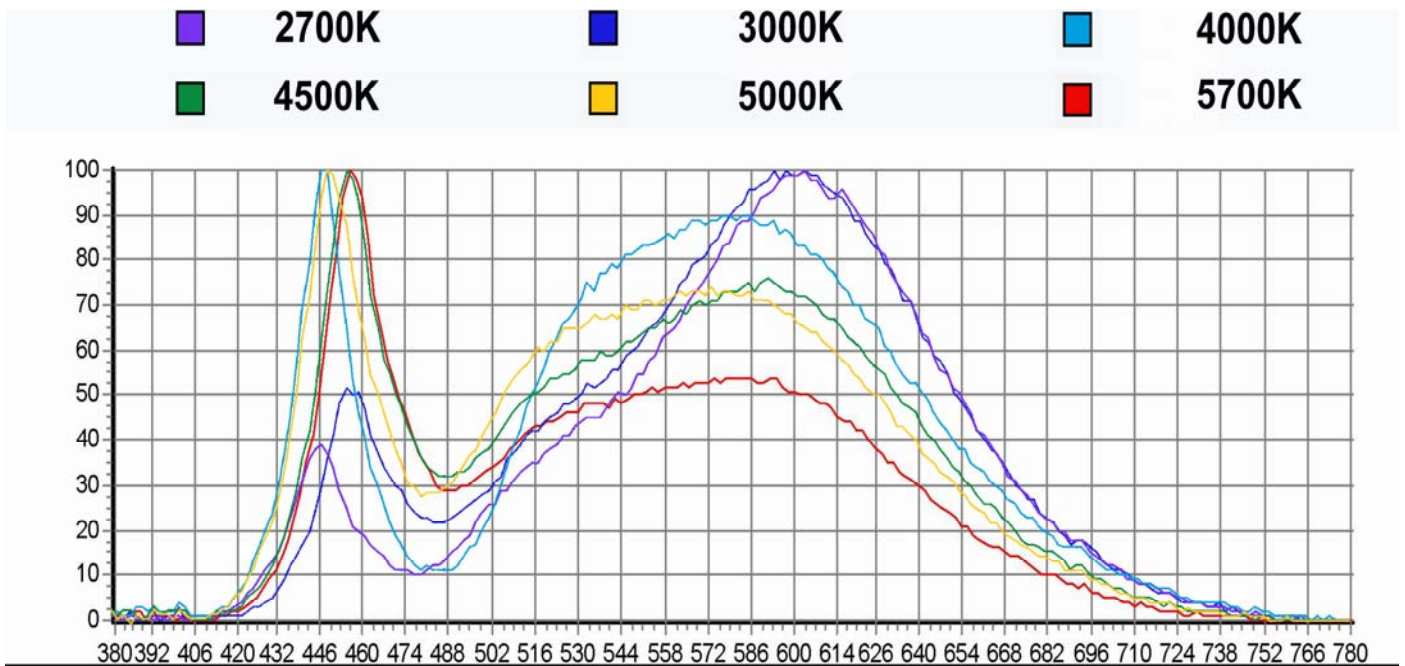

Temperature Characteristics

Relative Luminous (@320mA) VS. T_p Temperature

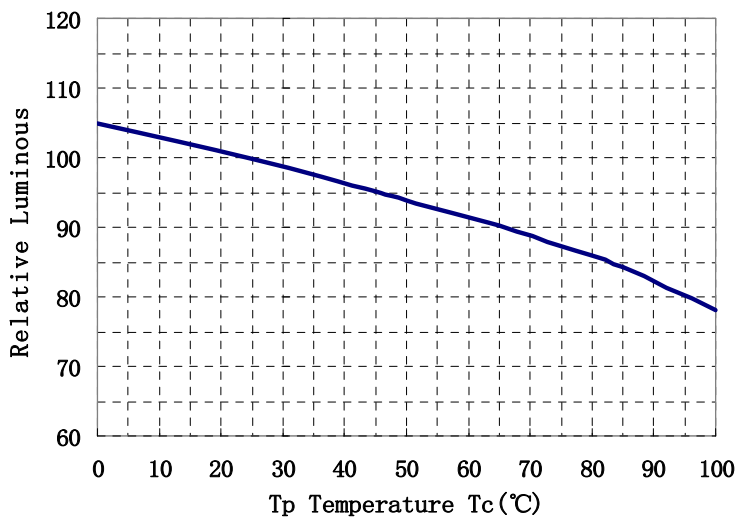

Forward Voltage (@320mA) VS. T_p Temperature

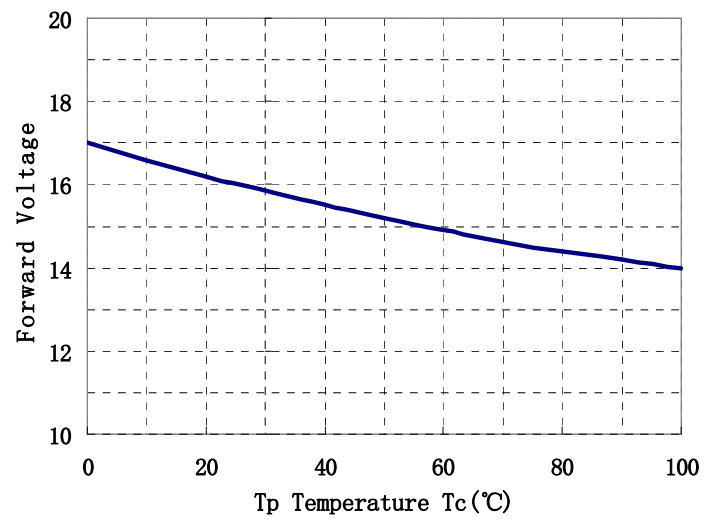

Please ensure the maintenance of heat radiation not to exceed T_p temperature over the rating in operation.

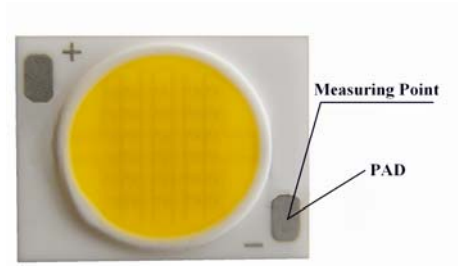

Electrical Characteristics

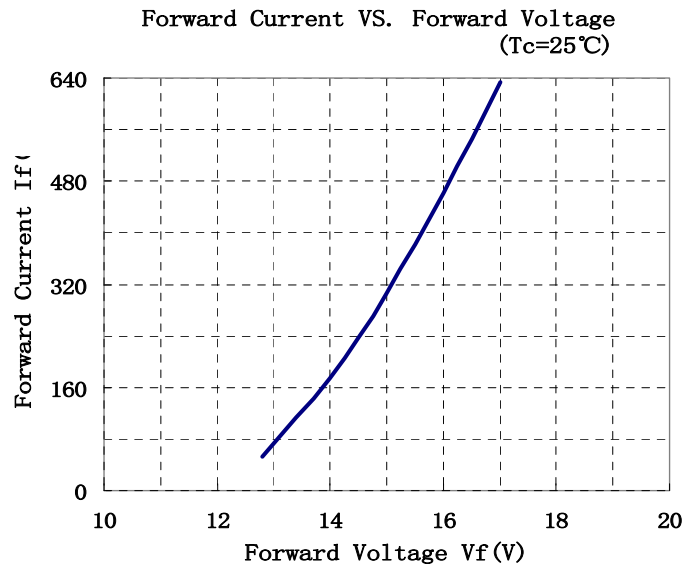
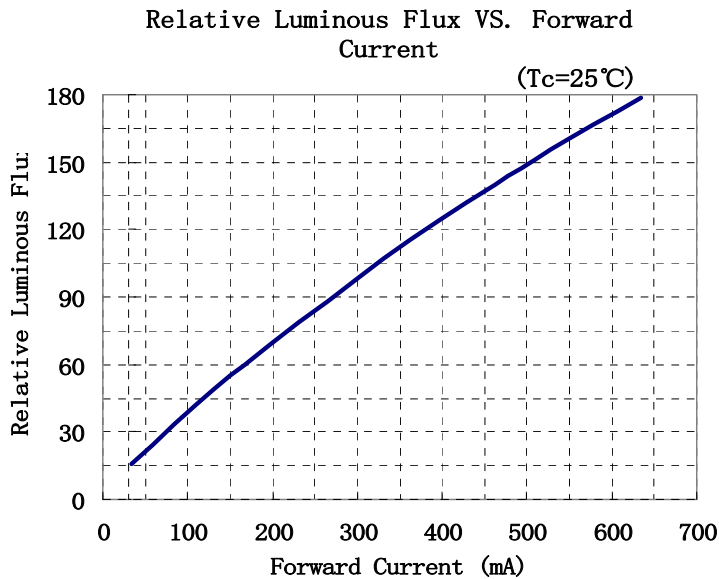

Derating Curves characteristics

Forward Current Derating Curve

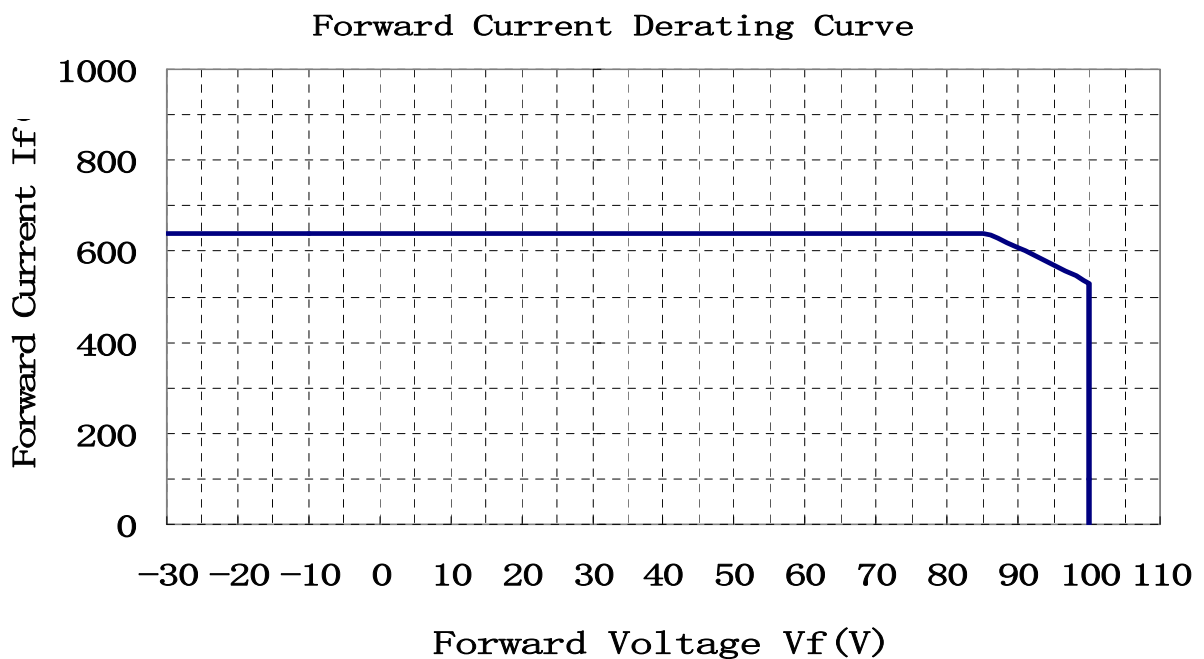

To keep Tp(PAD-temperature) lower than rating enough heat-radiation performance needs to be secured by using an adequate heat sink.

Typical Polar Radiation Pattern

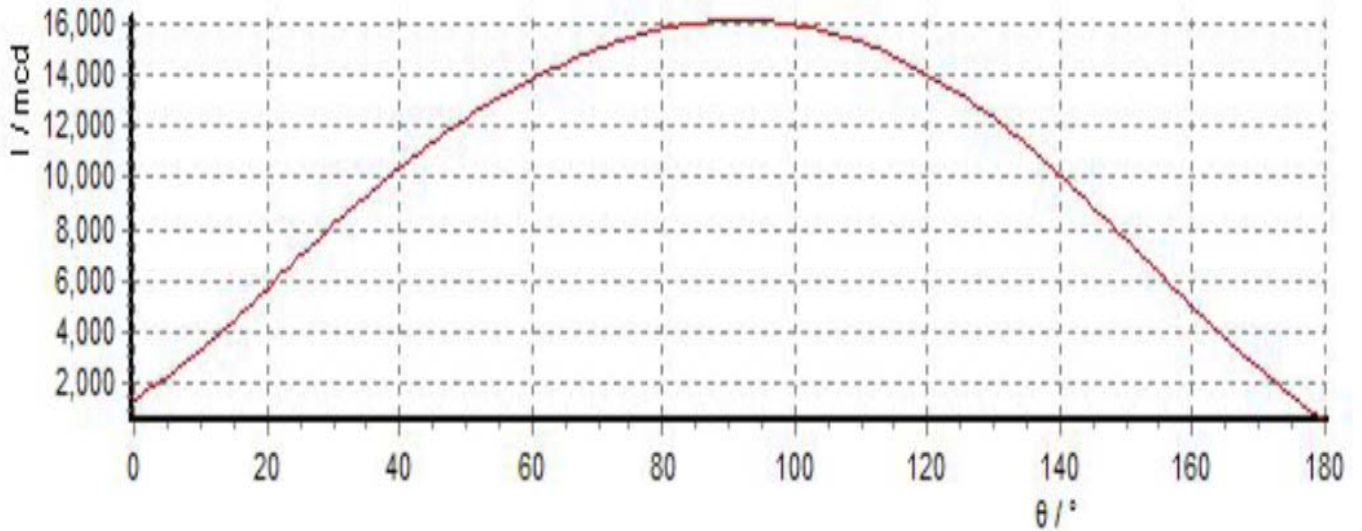

Typical Spatial Radiation Pattern

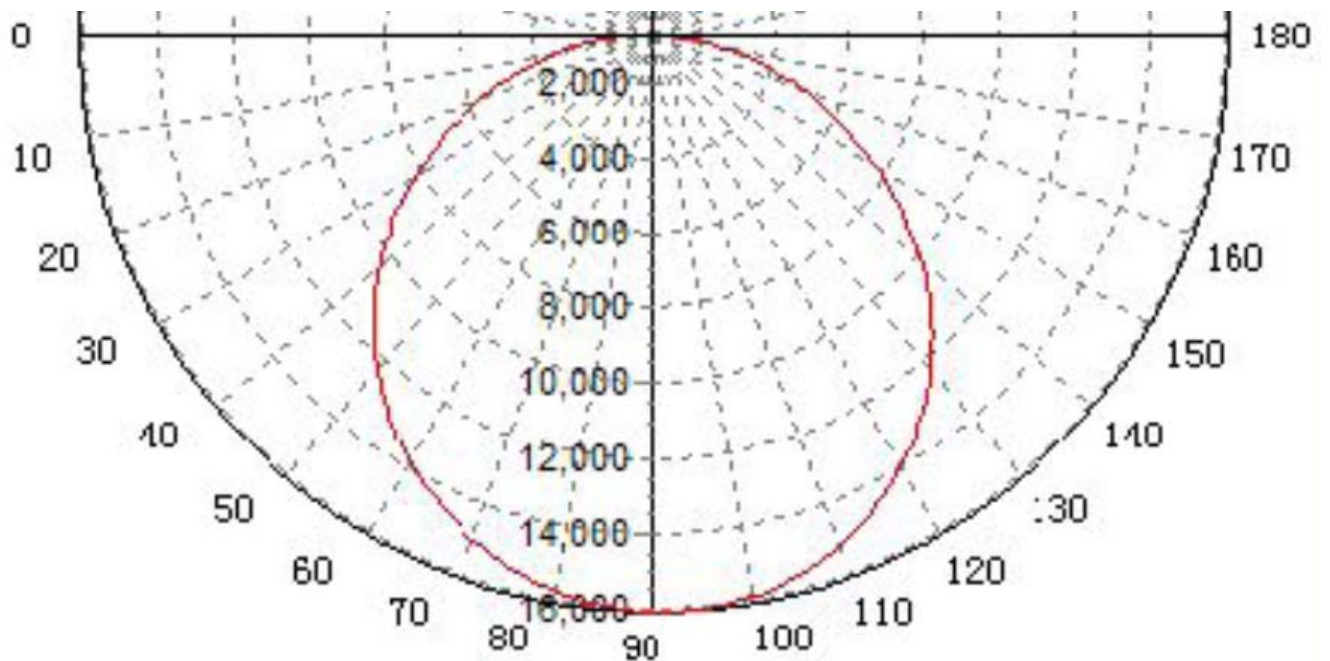

Typical Polar Radiation Pattern

Lightspot Electronics Technology Co., Ltd.

Order Code

L CS C 1215-05W0-xx xx F R80 0320- xxxx-xx
x1 x2 x3 x4 x5 x6 x7 x8 x9 x10 x11 x12

Part Number System :

X1: L-"Lightspot Ceramic COB"

X2: CB-COBER S series

X3: Shape of emitting surface:C-Circle R- Rectangle

X4: LED Outline: 1215-12mmx15mm

X5: LED Power. 05W0 represent5Watt

X6: Color temperature:(27、 30、 35、 40、 45、 50、 57、 65...)x100

X7: Chip specification,Factory used only

X8: Light efficiency (lm/W) 70lm/w≤**E**<90lm/w;90lm/w≤**F**< 110lm/w;110lm/w≤**G**<120lm/w;
120lm/w≤**H**<130lm/w; 130lm/w≤**J**<140lm/w

X9: Color rendering Index(CRI) : 60≤**R**60<65 ; 65≤**R**65<70 ; 70≤**R**70<75; 75≤**R**75<80 ;
80≤**R**80<85 ; 85≤**R**85<90 ; 90≤**R**90<95 ; 95≤**R**95<97 ; 97≤**R**98≤98 ;

X10: Default Forward Current(Vi). 0320 - 320mA

X11: Factory used only

X12: Chromaticity bin code

NOTICE:

- All dimensions are in millimeter.
- Tolerance is ±0.1mm unless otherwise noted.
- It is strongly recommended that the temperature of lead be not higher than 70°C.
- This information in this document is subject to change in order to improve reliability, design or function without prior notice and does not represent a commitment on the part of this company.

Avoids preserving in the high temperature, the high-moisture, as well as in the acidic environment .